



Forming Systems, Inc.
P.O. Box 694
Schoolcraft, MI 49087 USA

Phone: 877-727- FORM (3676)
269-679-3557 (International)
Fax: 269-679-3567
Email: info@formingsystemsinc.com

High Speed Wire Pay Off System VR 80

FEATURES:

- Available for extremely high speed wire feed.
- Motor brake ensures smooth wire feed in high speed.
- Advanced dancing arm designed for high speed purpose and easy operation.
- Self-auto stepless control ensures easy operation.
- Syncs speed control available.
- Motor running rate and current display on panel.
- Safety cover ready for spool.

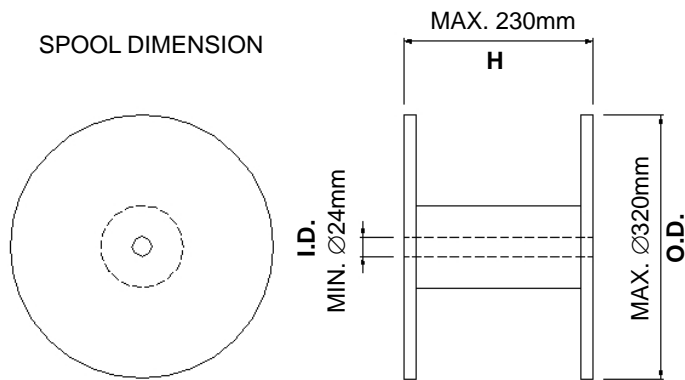

OPENABLE SAFETY COVER
WITH SHUT DOWN SWITCH

SPECIFICATION:

| MODEL | MAX LOAD OF MATERIAL | MAX SPEED OF TABLE | SPOOL DIMENSION | MAX. WIRE DIA. | DIMENSIONS (LxWxH) | WEIGHT |
|-------|----------------------|--------------------|---|---|---------------------------------|--------------------|
| VR 80 | 80KGS (180LBS) | 180 RPM | O.D. MAX. $\varnothing 320\text{mm}$ ($\varnothing 12.5''$) I.D. MIN. $\varnothing 24\text{mm}$ ($\varnothing 1.0''$) H MAX. 230mm (9.1") | $\varnothing 0.8\text{mm}$ ($\varnothing 0.031''$) | 720x780x1200mm (28"x30"x47") | 130KGS (290LBS) |



Manufacturer:

Huei Shang Industrial Co., Ltd.